

Overview	32
Gate Type- Bolted Bonnet- 150 lb., & 300 lb. valves	33
Gate Type- Bolted Bonnet- 600 lb. valves	34
Gate Type- Bolted Bonnet- 800 lb. & 1500 lb. valves	35
Gate Type- Bolted Bonnet- 1500 lb. valves Welded Bonnet- 150 lb.-1500 lb valves	36
Globe Type- Bolted Bonnet- 150 lb., & 300 lb. valves	37
Globe Type- Bolted Bonnet- 600 lb. valves	38
Globe Type- Bolted Bonnet- 800 lb. & 1500 lb. valves	39
Globe Type- Bolted Bonnet- 1500 lb. valves Welded Bonnet- 150 lb. & 1500 lb. valves ..	40

CRYOGENIC VALVES

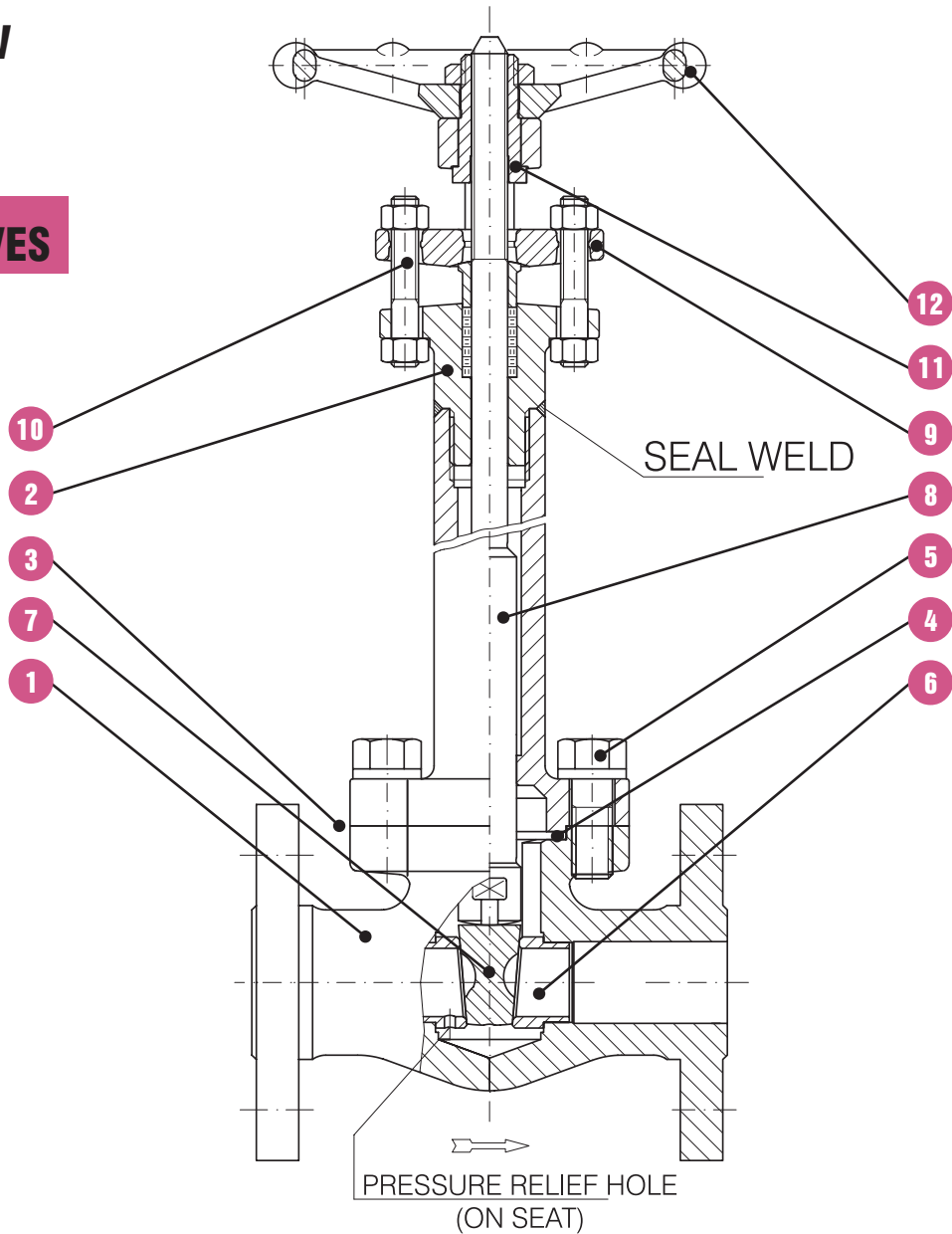

CRYOGENIC VALVES

Typical cryogenic gate valve shown. Forged steel, outside screw and yoke (OS&Y), rising stem, non-rising handwheel. Full or conventional port. Bolted or welded bonnet joint. Integral backseat.



- 1. BODY.** The body is forged steel and designed to the basic dimensional requirements of the applicable specifications such as API 602 and ASME B16.34. The body is available in both the full or conventional port design.
- 2. BONNET.** The bonnet is forged steel and extended to act as a gas column to keep stem packing at a sufficient distance away from the frost line. The bonnet also has an integral backseat and incorporates the stuffing box, which has dimensions per the applicable specifications such as API 602.
- 3. BODY-BONNET JOINT.** Two different bonnet joint designs are available. These are either the bolted bonnet or the threaded and seal welded type.
- 4. GASKET.** The bolted bonnet joint design valve uses a contained, controlled compression, spiral wound type gasket.
- 5. BONNET BOLTING.** The bonnet bolting is manufactured of alloy steel in accordance with the requirements of the applicable specifications such as API 602 and ASME B16.34.
- 6. SEAT RINGS.** The seat rings are steel and make up part of the valve trim. They are pressed into the valve body and wedged into place, forming a seal with the body. The seat ring is vented on the up-stream side to prevent high pressure build up if the temperature rises in the column. The seating surfaces are ground and lapped.
- 7. WEDGE.** The wedge, which is a solid design, is forged or investment cast steel and is part of the valve trim. The seating surfaces are ground and lapped.
- 8. STEM.** The stem is forged steel and part of the valve trim. It contains an integral back seat shoulder, which mates with the integral backseat of the bonnet. The stem is designed to the basic dimensional requirements of the applicable specifications such as API 602.
- 9. GLAND AND FLANGE.** The gland, gland flange assembly utilizes a separate, two piece design. This self aligning design allows the flange to be unevenly tightened while the gland maintains its parallel alignment with the stem and stuffing box.
- 10. GLAND BOLTS AND NUTS.** The steel/stainless steel gland bolt and nut assembly is a stud, double nut arrangement. This design allows complete removal from the valve when service is required. The use of industry standard thread full length studs and nuts also allows easy replacement should these items be lost or in need of replacement.
- 11. YOKE SLEEVE.** The yoke sleeve is of forged stainless steel material having a high melting point and is resistant to wear and corrosion.
- 12. HANDWHEEL.** The handwheel is forged carbon steel of an open spoke design. This robust construction along with appropriate sizing allows for ease of operation.

CRYOGENIC VALVES- GATE TYPE- BOLTED BONNET- FULL & REDUCED PORT

150 LB.

300 LB.

Design construction:

- API 602- ASME B16.34- BS 5352- BS 6364
- Testing according to API 598
- Marking MSS SP25
- Outside Screw and Yoke (OS&Y)
- Self aligning two piece packing gland
- Spiral wound gasket
- Integral backseat
- Face to face according to ASME B16.10
- Flanges according to ASME B16.5
- Welded body- bonnet joint also available
- Ratings: stainless steel A182- F316
 - class 150 = 275 psig @ 100°F
19 bar + 38°C
 - class 300 = 720 psig @ 100°F
49 bar + 38°C

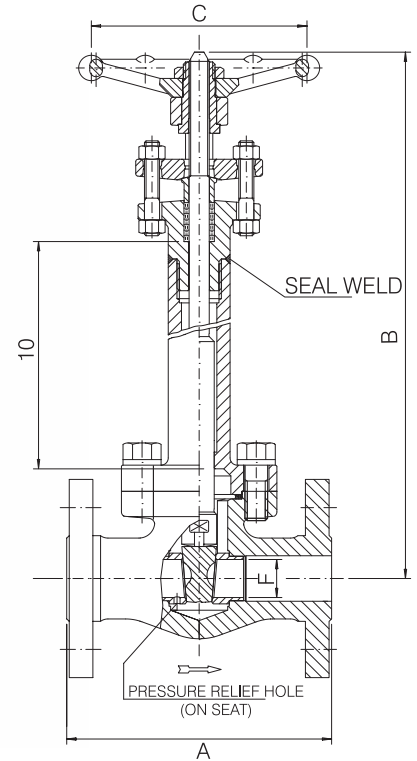

150 LB.						
FULL PORT – FIG. 1C 10						
SIZE	inch mm	1/2 15	3/4 20	1 25	1 1/2 40	2 50
A	inch mm	4.25 108	4.62 117.5	5 127	6.5 165	7.01 178
B open	inch mm	16.93 430	17.52 445	18.50 470	21.06 535	23.42 595
C	inch mm	3.46 88	3.82 97	5.43 138	5.43 138	6.77 172
F	inch mm	.55 14	.71 18	.94 24	1.44 36.6	1.89 48
Weight	lb. kg	10.5 4.8	13 5.9	19.25 8.7	32.5 14.7	42 19
PACKING		BH2	BH4	BH5	BY5	BY7
GASKET		G2	G3	G4	G7	G8

150 LB.						
REDUCED PORT – FIG. 1CL 10						
SIZE	inch mm	1/2 15	3/4 20	1 25	1 1/2 40	2 50
A	inch mm	4.25 108	4.62 117.5	5 127	6.5 165	7.01 178
B open	inch mm	16.54 420	17.13 435	17.72 450	20.08 510	21.06 535
C	inch mm	3.46 88	3.46 88	3.82 97	5.43 138	5.43 138
F	inch mm	.38 9.6	.55 14	.71 18	1.18 30	1.44 36.6
Weight	lb. kg	9.5 4.3	11.25 5.1	14 6.4	27.25 12.4	35.25 16
PACKING		BH2	BH2	BH4	BH6	BY5
GASKET		G2	G2	G3	G5	G7

300 LB.						
FULL PORT – FIG. 3C 10						
SIZE	inch mm	1/2 15	3/4 20	1 25	1 1/2 40	2 50
A	inch mm	5.51 140	6.00 152.5	6.5 165	7.52 191	8.50 216
B open	inch mm	16.93 430	17.52 445	18.50 470	21.06 535	23.42 595
C	inch mm	3.46 88	3.82 97	5.43 138	5.43 138	6.77 172
F	inch mm	.55 14	.71 18	.94 24	1.44 36.6	1.89 48
Weight	lb. kg	11.25 5.1	15.75 7.2	21.75 9.9	35.25 16	48.5 22
PACKING		BH2	BH4	BH5	BY5	BY7
GASKET		G2	G3	G4	G7	G8

300 LB.						
REDUCED PORT – FIG. 3CL 10						
SIZE	inch mm	1/2 15	3/4 20	1 25	1 1/2 40	2 50
A	inch mm	5.51 140	6.00 152.5	6.5 165	7.52 191	8.50 216
B open	inch mm	16.53 420	17.12 435	17.72 450	20.08 510	21.06 535
C	inch mm	3.46 88	3.46 88	3.82 97	5.43 138	5.43 138
F	inch mm	.38 9.6	.55 14	.71 18	1.18 30	1.44 36.6
Weight	lb. kg	11.25 5.1	14.25 6.5	17.25 7.8	33 15	42 19
PACKING		BH2	BH2	BH4	BH6	BY5
GASKET		G2	G2	G3	G5	G7



BONNEY FORGE

CRYOGENIC VALVES- GATE TYPE- BOLTED BONNET- FULL & REDUCED PORT

600 LB.

Design construction:

- API 602- ASME B16.34- BS 5352- BS 6364
- Testing according to API 598
- Marking MSS SP25
- Outside Screw and Yoke (OS&Y)
- Self aligning two piece packing gland
- Spiral wound gasket
- Integral backseat
- Face to face according to ASME B16.10
- Flanges according to ASME B16.5
- Welded body- bonnet Joint also available
- Ratings: stainless steel A182- F316
- class 600 = 1440 psig @ 100°F
- 99 bar + 38°C

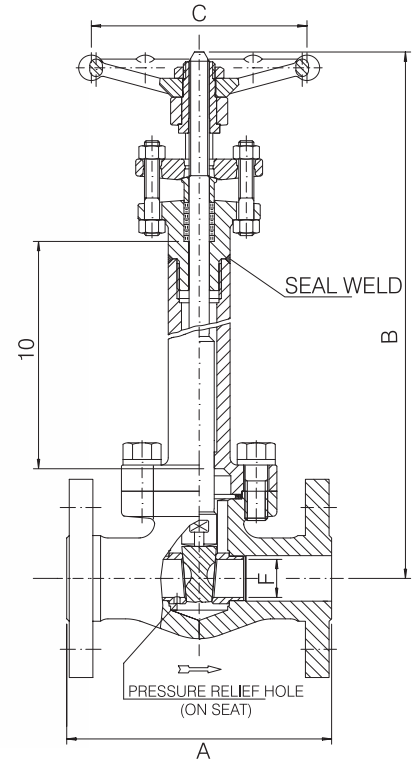

	FULL PORT – FIG. 6C 10								REDUCED PORT – FIG. 6CL 10						
	SIZE	inch mm	1/2 15	3/4 20	1 25	1 1/2 40	2 50		SIZE	inch mm	1/2 15	3/4 20	1 25	1 1/2 40	2 50
600 LB.	A	inch mm	6.5 165	7.52 191	8.50 216	9.49 241	11.5 292	600 LB.	A	inch mm	6.5 165	7.52 191	8.50 216	9.49 241	11.5 292
	B open	inch mm	16.93 430	17.52 445	18.50 470	21.06 535	23.42 595		B open	inch mm	16.53 420	17.12 435	17.72 450	20.08 510	21.06 535
	C	inch mm	3.46 88	3.82 97	5.43 138	5.43 138	6.77 172		C	inch mm	3.46 88	3.46 88	3.82 97	5.43 138	5.43 138
	F	inch mm	.55 14	.71 18	.94 24	1.44 36.6	1.89 48		F	inch mm	.38 9.6	.55 14	.71 18	1.18 30	1.44 36.6
	Weight	lb. kg	13.75 6.2	18.5 8.4	23 10.5	44 20	70.5 32		Weight	lb. kg	11.75 5.3	16.25 7.4	21.5 9.8	39.75 18	53 24
	PACKING		BH2	BH4	BH5	BY5	BH8		PACKING		BH2	BH2	BH4	BH6	BY5
	GASKET		G2	G3	G4	G7	G9		GASKET		G2	G2	G3	G6	G7

CRYOGENIC VALVES- GATE TYPE- BOLTED BONNET- FULL & REDUCED PORT

800 LB.

1500 LB.

Design construction:

- API 602- ASME B16.34- BS 5352- BS 6364
- Testing according to API 598
- Marking MSS SP25
- Outside Screw and Yoke (OS&Y)
- Self aligning two piece packing gland
- Spiral wound gasket
- Integral backseat
- Welded body- bonnet joint also available
- Socket Weld Ends to ASME B16.11
- Screwed Ends (NPT) to ASME B1.20.1
- Butt Welding Ends to ASME B16.25
- Ratings: Stainless steel A182- F316
 - class 800 1920 psig @ 100°F
132 bar + 38°C
 - class 1500 3600 psig @ 100°F
248 bar + 38°C

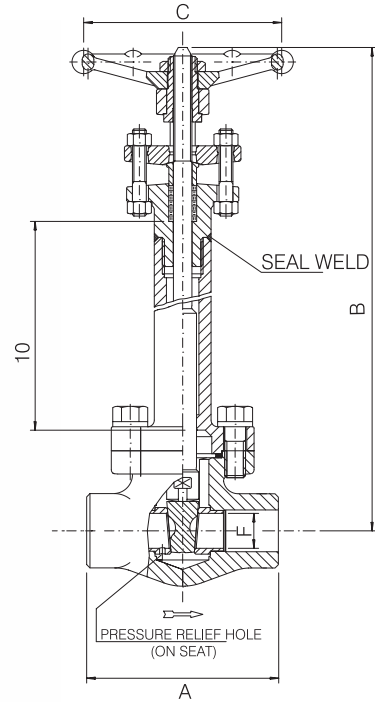

800 LB.		FULL PORT – FIG. C 10								
SIZE	inch mm	1/4 6	3/8 10	1/2 15	3/4 20	1 25	1 1/4 32	1 1/2 40	2 50	
A	inch mm	3.15 80	3.15 80	3.54 90	4.33 110	5 127	5 127	5 127	8.27 210	
B open	inch mm	15.75 400	15.75 400	15.75 400	17.52 445	18.70 475	19.88 505	20.87 530	23.54 598	
C	inch mm	3.46 88	3.46 88	3.46 88	3.82 97	5.43 138	5.43 138	5.43 138	6.77 172	
F	inch mm	.31 8	.38 9.6	.55 14	.71 18	.94 24	1.18 30	1.44 36.6	1.89 48	
G	inch mm	1.26 32	1.26 32	1.5 38	1.89 48	2.20 56	2.52 64	3.07 78	3.35 85	
Weight	lb. kg	7.5 3.4	7.5 3.4	7.75 3.5	11.25 5.1	18 8.2	26.5 12	35.25 16	50.75 23	
PACKING		BH2	BH2	BH2	BH4	BH5	BH6	BY5	BH8	
GASKET		G2	G2	G2	G3	G4	G6	G7	G9	

800 LB.		REDUCED PORT – FIG. CL 10					
SIZE	inch mm	1/2 15	3/4 20	1 25	1 1/2 40	2 50	
A	inch mm	3.15 80	3.54 90	4.33 110	5 127	5 127	
B open	inch mm	15.75 400	15.75 400	17.52 445	19.88 505	20.87 530	
C	inch mm	3.46 88	3.46 88	3.82 97	5.43 138	5.43 138	
F	inch mm	.38 9.6	.55 14	.71 18	1.18 30	1.44 36.6	
G	inch mm	1.26 32	1.5 38	1.89 48	2.52 64	3.07 78	
Weight	lb. kg	7.5 3.4	7.75 3.5	11 5	21 9.6	27.5 12.5	
PACKING		BH2	BH2	BH4	BH6	BY5	
GASKET		G2	G2	G3	G6	G7	

1500 LB.		FULL PORT – FIG. 9C 10								
SIZE	inch mm	1/4 6	3/8 10	1/2 15	3/4 20	1 25	1 1/4 32	1 1/2 40	2 50	
A	inch mm	3.54 90	3.54 90	4.33 110	5 127	5 127	5 127	8.27 210	9.05 230	
B open	inch mm	15.55 395	15.55 395	17.12 435	18.50 470	19.49 495	20.47 520	23.03 585	24.41 620	
C	inch mm	3.46 88	3.46 88	3.82 97	5.43 138	5.43 138	5.43 138	6.77 172	9.21 234	
F	inch mm	.31 8	.38 9.6	.55 14	.71 18	.94 24	1.18 30	1.44 36.6	1.89 48	
G	inch mm	1.5 38	1.5 38	1.89 48	2.20 56	2.52 64	3.07 78	3.35 85	3.74 95	
Weight	lb. kg	7.75 3.5	7.75 3.5	12 5.5	17 7.8	24.25 11	40 14.5	56.5 25.6	94.75 43	
PACKING		BH3	BH3	BH5	BH6	2B4	BY7	2B5	9B8	
GASKET		G1	G1	G2	G3	G4	G5	G7	G8	

1500 LB.		REDUCED PORT – FIG. 9CL 10					
SIZE	inch mm	1/2 15	3/4 20	1 25	1 1/2 40	2 50	
A	inch mm	3.54 90	4.33 110	5 127	5 127	8.27 210	
B open	inch mm	15.94 405	17.32 440	18.50 470	20.67 525	23.23 590	
C	inch mm	3.46 88	3.82 97	5.43 138	5.43 138	6.77 172	
F	inch mm	.38 9.6	.55 14	.71 18	1.18 30	1.44 36.6	
G	inch mm	1.26 32	1.5 38	1.89 48	2.52 64	3.07 78	
Weight	lb. kg	8 3.7	11.5 5.3	18.75 8.5	30 13.6	57.25 26	
PACKING		BH3	BH5	BH6	2B5	BH8	
GASKET		G1	G2	G3	G5	G7	

CRYOGENIC VALVES- GATE TYPE- BOLTED BONNET- FULL PORT

1500 LB.

Design construction:

- ASME B16.34- BS 5352
- Full Port type
- Testing according to API 598
- Marking MSS SP25
- Outside Screw and Yoke (OS&Y)
- Self aligning two piece packing gland
- Body bonnet gasket ring joint type
- Spiral wound type gasket on request
- Integral backseat
- Integral body flanges
- Face to face according to ASME B16.10
- Flanges according to ASME B16.5
- Welded body bonnet joint also available
- Ratings: stainless steel A182- F316
- class 1500 3600 psig @ 100°F
- 248 bar + 38°C

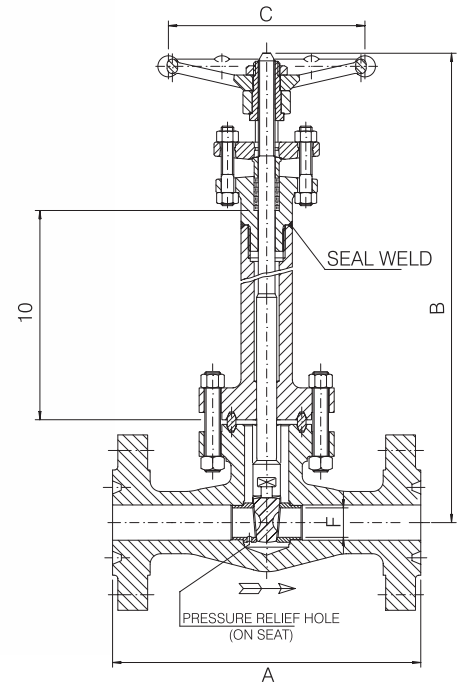

FULL PORT – FIG. 15CFR 10						
SIZE	inch mm	1/2 15	3/4 20	1 25	1 1/2 40	2 50
A	inch mm	8.50 216	9.01 229	10 254	12.01 305	14.62 371.5
B open	inch mm	17.91 455	19.29 490	19.68 500	22.64 575	24.80 630
C	inch mm	3.82 97	5.43 138	5.43 138	6.77 172	9.21 234
F	inch mm	.55 14	.71 18	.94 24	1.44 36.6	1.89 48
Weight	lb. kg	22.5 10,2	30.75 14	38.5 17,5	68.25 31	130 59
PACKING		BH5	BH6	2B4	BH8	4B8
GASKET		R12	R16	R16	R20	R22

Materials and trim specifications Page 91

TYPICAL DRAWING FOR GATE AND GLOBE WELDED BONNET CONSTRUCTION

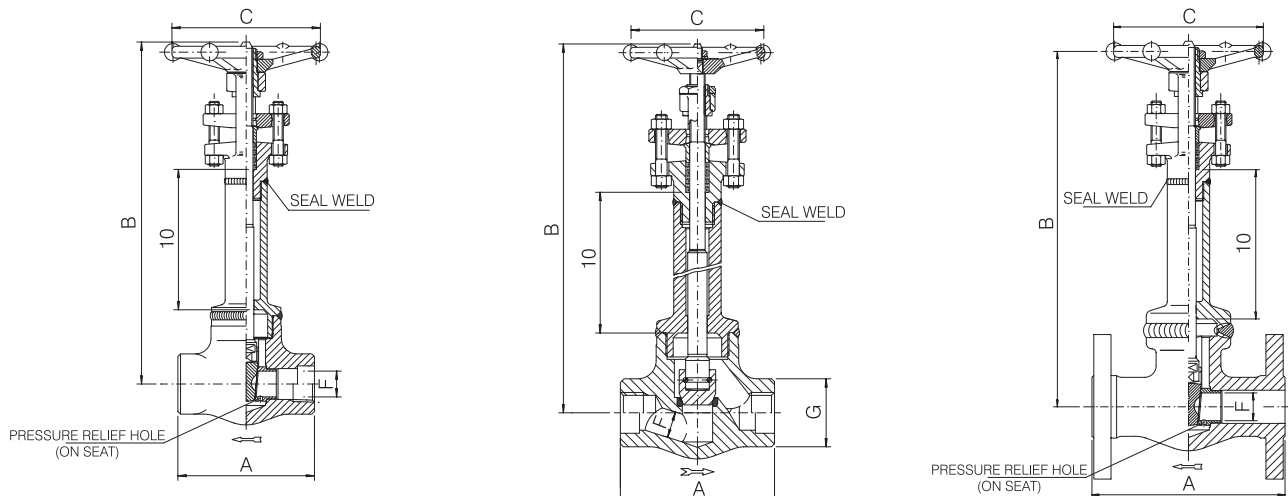

CRYOGENIC VALVES- GLOBE TYPE- BOLTED BONNET- FULL & REDUCED PORT

150 LB.

300 LB.

Design construction:

- ASME B16.34- BS 5352- BS 6364
- Testing according to API 598
- Marking MSS SP25
- Outside Screw and Yoke (OS&Y)
- Self aligning two piece packing gland
- Spiral wound gasket
- Integral backseat
- Loose disc stem assembly
- Integral body flanges
- Face to face according to ASME B16.10
- Flanges according to ASME B16.5
- Welded body - bonnet joint also available
- Ratings: stainless steel A182- F316
 - class 150 275 psig @ 100°F
19 bar + 38°C
 - class 300 720 psig @ 100°F
49 bar + 38°C

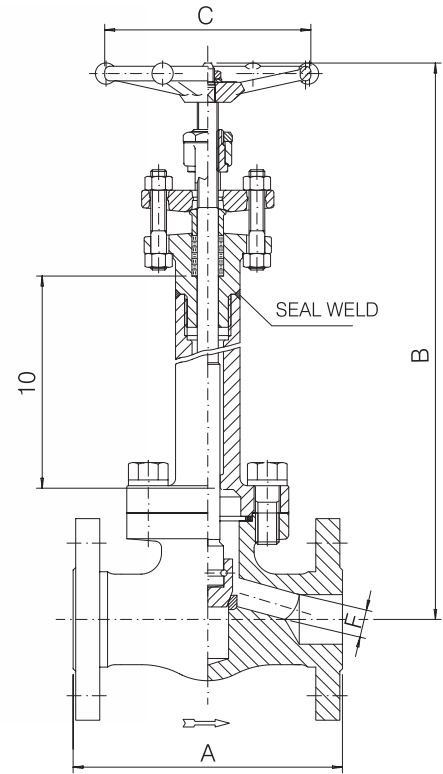

		FULL PORT – FIG. 1C 30					
SIZE	inch	1/2	3/4	1	1 1/2	2	
	mm	15	20	25	40	50	
A	inch	4.25	4.62	5	6.5	7.99	
	mm	108	117.5	127	165	203	
B open	inch	17.52	18.50	19.68	22.05	24.80	
	mm	445	470	500	560	630	
C	inch	3.46	3.82	5.43	5.43	6.77	
	mm	88	97	138	138	172	
F	inch	.51	.69	.88	1.38	1.77	
	mm	13	17.5	22.5	35	45	
Weight	lb.	10.5	13	19.25	32.5	46.25	
	kg	4.8	5.9	8.7	14.7	21	
PACKING		BH3	BH5	BY5	BY7	BY7	
GASKET		G2	G3	G4	G7	G8	

		REDUCED PORT – FIG. 1CL 30					
SIZE	inch	1/2	3/4	1	1 1/2	2	
	mm	15	20	25	40	50	
A	inch	4.25	4.62	5	6.5	7.99	
	mm	108	117.5	127	165	203	
B open	inch	15.16	17.12	18.11	20.27	21.46	
	mm	385	435	460	515	545	
C	inch	3.46	3.46	3.82	5.43	6.77	
	mm	88	88	97	138	172	
F	inch	.35	.51	.69	1.16	1.38	
	mm	9	13	17.5	29.5	35	
Weight	lb.	10	11.5	14.75	27.5	42	
	kg	4.6	5.2	6.7	12.5	19	
PACKING		BH3	BH3	BH5	BY5	BY7	
GASKET		G2	G2	G3	G5	G8	

		FULL PORT – FIG. 3C 30					
SIZE	inch	1/2	3/4	1	1 1/2	2	
	mm	15	20	25	40	50	
A	inch	6.00	7.01	7.99	9.01	10.51	
	mm	152.5	178	203	229	267	
B open	inch	16.53	18.11	20.08	21.65	24.01	
	mm	420	460	510	550	610	
C	inch	3.46	3.82	5.43	6.77	6.77	
	mm	88	97	138	172	172	
F	inch	.51	.69	.88	1.38	1.77	
	mm	13	17.5	22.5	35	45	
Weight	lb.	13.75	17.5	26.5	46.25	68.25	
	kg	6.2	7.9	12	21	31	
PACKING		BH3	BH5	BY5	BY7	BH8	
GASKET		G2	G3	G4	G7	G9	

		REDUCED PORT – FIG. 3CL 30					
SIZE	inch	1/2	3/4	1	1 1/2	2	
	mm	15	20	25	40	50	
A	inch	6.00	7.01	7.99	9.01	10.51	
	mm	152.5	178	203	229	267	
B open	inch	15.35	17.32	18.90	21.26	22.24	
	mm	390	440	480	540	565	
C	inch	3.46	3.46	3.82	5.43	6.77	
	mm	88	88	97	138	172	
F	inch	.35	.51	.69	1.16	1.38	
	mm	9	13	17.5	29.5	35	
Weight	lb.	12.25	14.75	21.5	38.5	54	
	kg	5.6	6.7	9.8	17.5	24.5	
PACKING		BH3	BH3	BH5	BY5	BY7	
GASKET		G2	G2	G3	G6	G7	

CRYOGENIC VALVES- GLOBE TYPE- BOLTED BONNET- FULL & REDUCED PORT

600 LB.

Design construction:

- ASME B16.34- BS 5352- BS 6364
- Testing according to API 598
- Marking MSS SP25
- Outside Screw and Yoke (OS&Y)
- Self aligning two piece packing gland
- Spiral wound gasket
- Integral backseat
- Loose disc stem assembly
- Integral body flanges
- Face to face according to ASME B16.10
- Flanges according to ASME B16.5
- Welded body - bonnet joint also available
- Ratings: stainless steel A182 - F316
- class 600 1440 psig @ 100°F
- 99 bar + 38°C

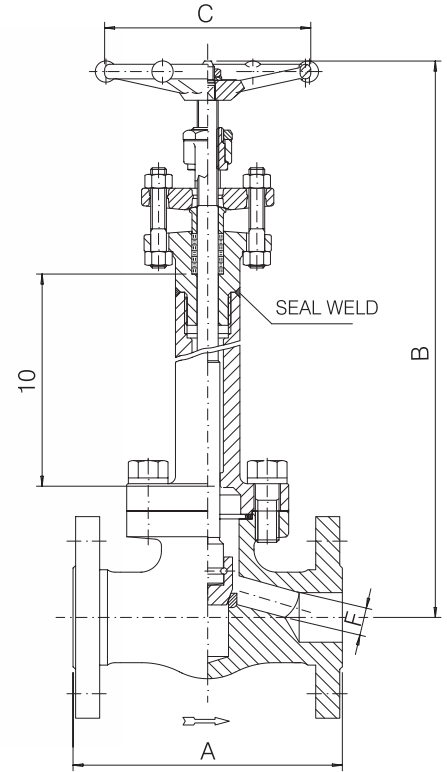

600 LB.								FULL PORT — FIG. 6C 30						
SIZE	inch mm	1/2 15	3/4 20	1 25	1 1/2 40	2 50								
A	inch mm	6.5 165	7.52 191	8.50 216	9.49 241	11.5 292								
B open	inch mm	16.53 420	18.11 460	20.08 510	21.65 550	24.01 610								
C	inch mm	3.46 88	3.82 97	5.43 138	6.77 172	6.77 172								
F	inch mm	.51 13	.69 17.5	.88 22.5	1.38 35	1.77 45								
Weight	lb. kg	14.25 6.5	19.25 8.7	27.75 12.6	48.5 22	75 34								
PACKING		BH3	BH5	BY5	BY7	BH8								
GASKET		G2	G3	G4	G7	G9								

600 LB.								REDUCED PORT — FIG. 6CL 30						
SIZE	inch mm	1/2 15	3/4 20	1 25	1 1/2 40	2 50								
A	inch mm	6.5 165	7.52 191	8.50 216	9.49 241	11.5 292								
B open	inch mm	15.35 390	17.32 440	18.90 480	21.26 540	22.24 565								
C	inch mm	3.46 88	3.46 88	3.82 97	5.43 138	6.77 172								
F	inch mm	.35 9	.51 13	.69 17.5	1.16 29.5	1.38 35								
Weight	lb. kg	13 5.9	16.75 7.6	22.5 10.2	42 19	57.25 26								
PACKING		BH3	BH3	BH5	BY5	BY7								
GASKET		G2	G2	G3	G6	G7								

B CRYOGENIC VALVES- GLOBE TYPE- BOLTED BONNET- FULL & REDUCED PORT

BONNEY FORGE

800 LB.

1500 LB.

Design construction:

- ASME B16.34- BS5352- BS6364
- Testing according to API 598
- Marking MSS SP25
- Outside Screw and Yoke (OS&Y)
- Self aligning two piece packing gland
- Spiral wound gasket
- Integral backseat
- Loose disc stem assembly
- Socket Weld Ends to ASME B16.11
- Screwed Ends (NPT) to ASME B1.20.1
- Butt Welding Ends to ASME B16.25
- Welded body - bonnet joint also available
- Ratings: stainless steel A182- F316
 - class 800 1920 psig @ 100°F
132 bar + 38°C
 - class 1500 3600 psig @ 100°F
248 bar + 38°C

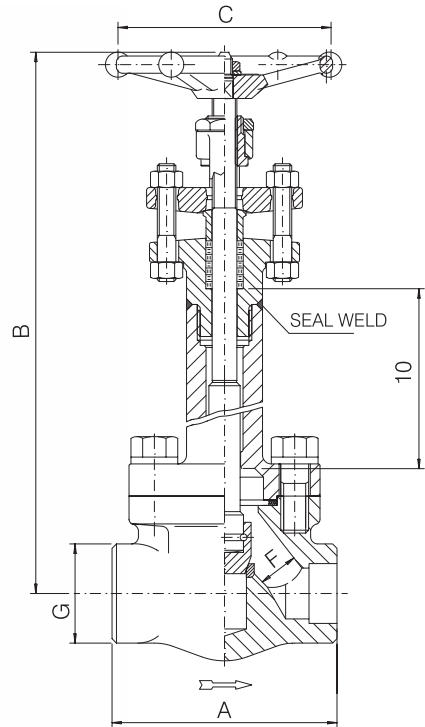

800 LB.		FULL PORT – FIG. C 30								
SIZE	inch mm	1/4 6	3/8 10	1/2 15	3/4 20	1 25	1 1/4 32	1 1/2 40	2 50	
A	inch mm	3.15 80	3.15 80	3.54 90	4.33 110	5 127	5.90 150	7.09 180	8.27 210	
B open	inch mm	16.34 415	16.34 415	16.53 420	18.11 460	19.49 495	19.88 505	21.26 540	24.21 615	
C	inch mm	3.46 88	3.46 88	3.46 88	3.82 97	5.43 138	5.43 138	6.77 172	6.77 172	
F	inch mm	.27 7	.35 9	.51 13	.69 17.5	.88 22.5	1.16 29.5	1.38 35	1.77 45	
G	inch mm	1.26 32	1.26 32	1.5 38	1.89 48	2.20 56	2.52 64	3.07 78	3.35 85	
Weight	lb. kg	7.75 3.5	7.75 3.5	8 3.6	11.25 5.1	18.5 8.4	27.75 12.6	36.25 16.5	53 24	
PACKING		BH3	BH3	BH3	BH5	BY5	BY5	BY7	BH8	
GASKET		G2	G2	G2	G3	G4	G6	G7	G9	

800 LB.		REDUCED PORT – FIG. CL 30					
SIZE	inch mm	1/2 15	3/4 20	1 25	1 1/2 40	2 50	
A	inch mm	3.15 80	3.54 90	4.33 110	5.90 150	7.09 180	
B open	inch mm	16.34 415	16.53 420	18.11 460	19.92 506	21.26 540	
C	inch mm	3.46 88	3.46 88	3.82 97	5.43 138	6.77 172	
F	inch mm	.35 9	.51 13	.69 17.5	1.16 29.5	1.38 35	
G	inch mm	1.26 32	1.5 38	1.89 48	2.52 64	3.07 78	
Weight	lb. kg	7.25 3.3	8.25 3.8	11.5 5.2	21.5 9.8	32.5 14.8	
PACKING		BH3	BH3	BH5	BY5	BY7	
GASKET		G2	G2	G3	G6	G7	

1500 LB.		FULL PORT – FIG. 9C 30								
SIZE	inch mm	1/4 6	3/8 10	1/2 15	3/4 20	1 25	1 1/4 32	1 1/2 40	2 50	
A	inch mm	3.54 90	3.54 90	4.33 110	5 127	5.90 150	7.09 180	8.27 210	9.05 230	
B open	inch mm	16.14 410	16.14 410	17.91 455	19.49 495	19.68 500	21.26 540	24.21 615	25.39 645	
C	inch mm	3.46 88	3.46 88	3.82 97	5.43 138	5.43 138	6.77 172	6.77 172	9.21 234	
F	inch mm	.27 7	.35 9	.47 12	.59 15	.79 20	1.06 27	1.26 32	1.57 40	
G	inch mm	1.5 38	1.5 38	1.89 48	2.20 56	2.52 64	3.07 78	3.35 85	3.74 95	
Weight	lb. kg	8.75 4	8.75 4	12 5.5	17.5 8	24.25 11	34 15.5	55 25	90.25 41	
PACKING		BH3	BH3	BH5	2B4	2B4	2B5	BH8	9B8	
GASKET		G1	G1	G2	G3	G4	G5	G7	G8	

1500 LB.		REDUCED PORT – FIG. 9CL 30					
SIZE	inch mm	1/2 15	3/4 20	1 25	1 1/2 40	2 50	
A	inch mm	3.54 90	4.33 110	5.90 150	7.09 180	8.27 210	
B open	inch mm	16.34 415	17.91 455	19.61 498	21.65 550	24.21 615	
C	inch mm	3.46 88	3.82 97	5.43 138	6.77 172	6.77 172	
F	inch mm	.35 9	.47 12	.59 15	1.06 27	1.26 32	
G	inch mm	1.5 38	1.89 48	2.20 56	3.07 78	3.35 85	
Weight	lb. kg	8 3.7	12 5.4	19.5 8.9	34.75 15.8	60.5 27.5	
PACKING		BH3	BH5	2B4	2B5	BH8	
GASKET		G1	G2	G3	G5	G7	

CRYOGENIC VALVES- GLOBE TYPE- BOLTED BONNET- FULL PORT

1500 LB.

Design construction:

- ASME B16.34- BS 5352- BS6364
- Testing according to API- 598
- Marking MSS- SP25
- Outside Screw and Yoke (OS&Y)
- Self aligning two piece packing gland
- Body bonnet gasket ring joint type
- Spiral wound type gasket on request
- Integral backseat
- Loose disc stem assembly
- Integral body flanges
- Face to face according to ASME B16.10
- Flanges according to ASME B16.5
- Welded body bonnet joint also available
- Full port type
- Ratings: stainless steel A182- F316
- class 1500 3600 psig @ 100°F
- 248 bar + 38°C

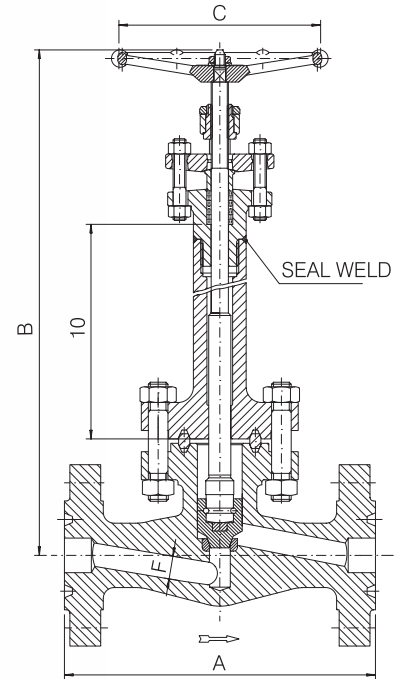

FULL PORT – FIG. 15CFR 30						
SIZE	inch	1/2	3/4	1	1 1/2	2
	mm	15	20	25	40	50
A	inch	8.50	9.01	10	12.01	14.62
	mm	216	229	254	305	371.5
B open	inch	18.50	20.08	20.67	23.42	25.59
	mm	470	510	525	595	650
C	inch	3.82	5.43	5.43	6.77	9.21
	mm	97	138	138	172	234
F	inch	.47	.57	.75	1.22	1.57
	mm	12	14.5	19	31	40
Weight	lb.	23	30.75	40.75	71.75	136.75
	kg	10,5	14	18,5	32,5	62
PACKING		BH5	2B4	2B4	BH8	9B8
GASKET		R12	R16	R16	R20	R22

Materials and trim specifications Page 91

TYPICAL DRAWING FOR GATE AND GLOBE WELDED BONNET CONSTRUCTION

